

## DISPLAY MEASURING SYSTEM

*Krasimir Velinov*

*University of Mining and Geology "St. Ivan Rilski", 1700 Sofia, candela@mail.bg, <http://light-bg.eu/>*

**ABSTRACT.** The development of modern technologies has allowed the creation of increasingly sophisticated systems for visualizing information. The evolution of the technology in this area has taken place in the following sequence: CRT, LCD, LED, OLED, AMOLED. Within the existing LCD, LED, OLED, AMOLED technologies, 2D, 3D and holographic displays can be developed. A team of engineers from the European Union are engaged in the development of elements of this technology. For this purpose, the Optintegral project has been activated with the idea of developing better and more modern LED display displays using the use of pressurized injection molding. Optintegral's goal is to demonstrate the feasibility of technology, flexibility, resilience and cost savings in this revolutionary manufacturing process. This will enable the competitive production of a wide range of LED displays within the European labor market. The consortium includes nine European partners from 5 European countries, including Fundació Privada Ascamm (ASCAMM), Simulacions Optiques SL (SNELL) and Spain's Spanish Association for Standardization and Certification (AENOR), VTT Technical Research Center of Finland (VTT) Neonelektro Oy (NEO) from Finland, LumyComp Design Ltd. (LUMY) and Megatex Commerce Ltd (MEGATEX) from Bulgaria, Holografika Hologramelbállító Fejlesztő és Forgalmazó Kft. (HOLOGRAFIKA) from Hungary and UBATH from the United Kingdom. In order to evaluate the qualities of the constructed modules and displays, a system to measure their parameters has been developed at the NIL "Lighting Engineering" at the University of Mining and Geology "St. Ivan Rilski". The system is a set of optical measuring equipment and a specially designed and manufactured coordinate table with a JETI specbos 1201 spectrometer mounted. The coordinate table has dimensions of 1300x1400 mm and allows measurement of displays up to 1200x1200 mm. The shifting of both axes X and Y is accomplished by two stepping motors. For testing, a measurement methodology has been compiled in accordance with current regulatory documents. With the measurement system so constructed, control measurements of a LED module.

**Keywords:** display, measuring system

### СИСТЕМА ЗА ИЗМЕРВАНЕ НА ДИСПЛЕИ

*Красимир Велинов*

*Минно-геоложки университет "Св. Иван Рилски", 1700 София, candela@mail.bg, <http://light-bg.eu/>*

**РЕЗЮМЕ.** Развитието на съвременните технологии позволява създаване на все по-съвършени ситеми за визуализиране на информацията. Еволюцията на технологиите в тази област протича в следната последователност: CRT, LCD, LED, OLED, AMOLED. В рамките на съществуващите технологии LCD, LED, OLED, AMOLED могат да се разработят 2D, 3D и холографски дисплеи. Екип инженери от Европейския съюз са се заели с разработката на елементи от тази технология. За целта е активиран проектът Optintegral с идеята да се разработят по-добри и модерни рекламни LED дисплеи, като се използва технологията на хибридно интегриране чрез шприцване под налягане. Целта на Optintegral е да се докаже приложимостта на технологията, да се демонстрира гъвкавостта, устойчивостта и намаляването на разходите при този революционен производствен процес. Това ще даде възможност за конкурентноспособно производство на широк кръг от разнообразни LED дисплеи в рамките на европейския трудов пазар. Консорциумът включва девет европейски партньори от 5 европейски страни, в това число Fundació Privada Ascamm (ASCAMM), Simulacions Optiques S.L.(SNELL) и Испанската асоциация по стандартизация и сертификация (AENOR), Центъра за технически проучвания (VTT) и Neonelektro Oy (NEO) от Финландия, LumyComp Design Ltd. (LUMY) и Megatex Commerce Ltd.(MEGATEX) от България, Holografika Hologramelbállító Fejlesztő és Forgalmazó Kft.(HOLOGRAFIKA) от Унгария и Университета в Бат (UBATH) от Обединеното Кралство (UK). За да се направи оценка на качествата на конструирани модули и дисплеи, в НИЛ "Осветителна техника" при Минно-геоложкия университет "Св. Иван Рилски" беше създадена система за измерване на параметрите им. Системата представлява набор от апаратура за оптични измервания и специално конструирана и изработена координатна маса с монтиран спектрометричния JETI specbos 1201. Координатната маса е с размери 1300x1400 мм и позволява измерване на дисплеи до размер 1200x1200 мм. Преместването по двете оси X и Y се осъществява от два стъпкови двигателя. За провеждане на изпитанията е съставена методика за измерване в съответствие с действащите в момента нормативни документи. С така създадената измервателна система са извършени контролни измервания на светодиоден модул, предназначен за изработка на дисплеи. Създадената измервателна система е тествана, като са извършени контролни измервания на светодиоден модул, предназначен за изработка на дисплеи. Тестовите са показали нейната работоспособност. Направени са препоръки за бъдеща работа.

**Ключови думи:** дисплей, измервателни системи

### Introduction

For a relatively short period of time, I have witnessed how technical devices for visual information have changed. Initially, these were CRT displays for displaying textual information, but it quickly came to the idea that a picture was more powerful than the text, and the first PCs had the ability to display graphical images. The quality was cryptic - a screen resolution of 320x240 dots and a monochrome image. Things changed, however, as in 1986, the most common computer had a

standard display with a resolution of 640x480 tp. The most common screen resolution currently is from 1280x1024 t to 1920x1200 t.

The development of state-of-the-art technologies has allowed us to create increasingly sophisticated systems for visualizing information. The evolution of the technology in this area was performed in the following sequence: CRT, LCD, LED, OLED, AMOLED. The last three technologies have enabled an even higher resolution - full-color 4K - 4096 x 3112 dots, with low energy costs.

In August 2016, Japan's national television company, NHK, launched the world's first regular 8K satellite broadcasting. The Super Hi-Vision Test Channel ran on Aug. 2 with a picture resolution of 7,680 to 4,320 pixels. Last September, Sharp presented a 85-inch receiver with a resolution of \$ 133,000. [1]

The processing of such an image requires large computational power. At the SIGGRAPH 2016 event, the AMD Radeon Pro graphics card has demonstrated an equivalent monitor resolution of 16K - 15,360 x 8640 (132 megapixels) [2].

Within the existing LCD, LED, OLED, AMOLED technologies, 2D, 3D and holographic displays can be developed. A team of engineers from the European Union are engaged in the development of elements of this technology. For this purpose, the OptIntegral project has been activated with the idea of developing better and more modern LED displays using the use of pressurized injection molding.

OptIntegral's goal is to demonstrate the feasibility of technology, demonstrate flexibility, sustainability and cost savings in this revolutionary manufacturing process. This will enable the competitive production of a wide range of LED displays within the European labor market. OptIntegral will initially develop three different prototypes of large-scale displays - 3D glasses-free, lightpipe Displays and LED direct-illuminated displays - designed for the store network, for transport and hotels. These prototypes of displays will be produced and demonstrated by three European SMEs and an effective impact on observers will be tested and evaluated through the use of state-of-the-art medical computerized imaging technologies with EEG enrollment. OptIntegral: This is a three-year project, launched on 01.02.2015 with funding provided by the European Union amounting to 5,675,337 Euros. The consortium includes nine European partners from 5 countries, including Fundació Privada Ascamm (ASCAMM), Simulacions Optiques SL (SNELL) and Spain's Spanish Association for Standardization and Certification (AENOR), VTT Technical Research Center of Finland (VTT) Neonelektro Oy (NEO) from Finland, LumyComp Design Ltd. (LUMY) and Megatex Commerce Ltd. (MEGATEX) from Bulgaria, Holografika Hologramelőállító Fejlesztő és Forgalmazó Kft. (HOLOGRAFIKA) from Hungary and the UBATH University of the United Kingdom (UK).



In order to evaluate the qualities of the constructed modules and displays a system has been developed to measure their parameters in the Lab "Lighting Engineering" at the University of Mining and Geology "St. Ivan Rilski".



The work was done in the following sequence:

1. Buying standards describing the testing methodology of 2D, 3D and holographic displays.
2. Creating a test methodology
3. Construction of an apparatus and a system of measuring instruments to perform the tests.

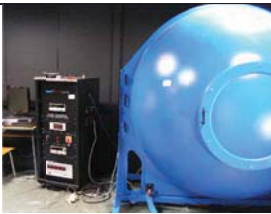
### Description of a display measurement system

To carry out the measurements a complete system was used with the following equipment:

LMT Photometer B520, ID 04B4021	
luminance-meter L 1003 of angular field 1°, producer "LMT" Germany, ID 0686191	
Automated goniophotometer	
Power Meter HM8115-2 ID 015447345	
Stabilized power supply ZAFV1.5/270;	
Digital multimeter DMM4050;	
Ulbricht photometer with diameter 2m	
Laser rangefinder DLE-40	

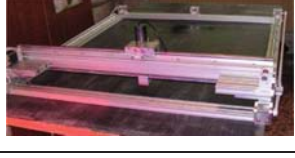
spectroradiometer JETI specbos 1201;	
Pulse light meter	
Automated display measuring table	
Spreadsheet generator	

In order to carry out the measurements, a coordinate table was constructed, on which spectrometer JETI specbos 1201 (Figure 1) was mounted. The coordinate table has a size of 1300x1400 mm and allows measurement of displays up to 1200x1200 mm. The displacement on both axes X and Y is accomplished by two stepping motors.



Fig. 1. Coordinate table for measuring displays

A suitable software was developed for coordinate table management and reading of the spectroradiometer data.

With the system so constructed, the following tests can be carried out:

- Measuring the viewing angle and distribution of brightness in the space;
- Measuring the pulsation coefficient of light;
- Measurement of white light chromaticity and its uniformity in liquid crystal display and devices with built-in backlighting system;
- Reproduction of colors;

The test methodology has been compiled in accordance with the documents [3 - 13]. In Fig. 2 and Fig. 3. the conditions under which the measurements are made are shown.

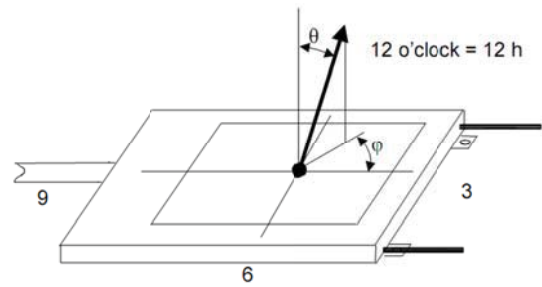

Fig. 2. Definition of polar coordinates  $\theta\phi$

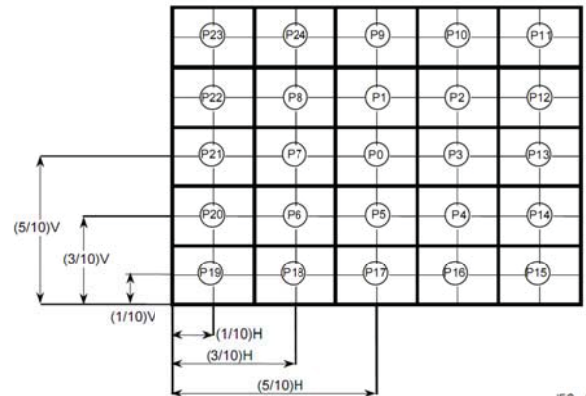

Fig. 3. Standard measurement positions in the centers of all rectangles P0-P24

## Results

With the measurement system so constructed, control measurements of a LED module designed for display were made. The photo of the module is shown in Fig. 4.

Luminous flux emitted from the 37 lm module.

Distribution of brightness on the red color display, cd/sqm

66.4	68.5	75.1
47.0	73.0	64.0

Minimum value = 47.0 cd/sqm  
Average value = 65.7 cd/sqm  
Uniformity – U<sub>0</sub> = 0.72

275	289	289
185	252	186

Minimum value = 185 cd/sqm  
Average value = 246 cd/sqm  
Uniformity – U<sub>0</sub> = 0.75  
Brightness distribution on blue color display, cd/sqm

49.7	50.2	49.9
36.7	47.5	29.4

Minimum value = 29.4 cd/sqm  
Average value = 43.9 cd/sqm  
Uniformity – U<sub>0</sub> = 0.67  
Brightness distribution on white, cd/sqm

352	372	363
234	406	235

Minimum value = 234 cd/sqm  
 Average value = 327 cd/sqm  
 Uniformity –  $U_0 = 0.72$   
 Brightness in the middle of the bright segment = 220 cd/sqm  
 Brightness in the middle of the dark segment = 0.75 cd/sqm  
 Brightness at the end of the bright segment = 137 cd/sqm  
 Brightness at the end of the dark segment = 20.3 cd/sqm

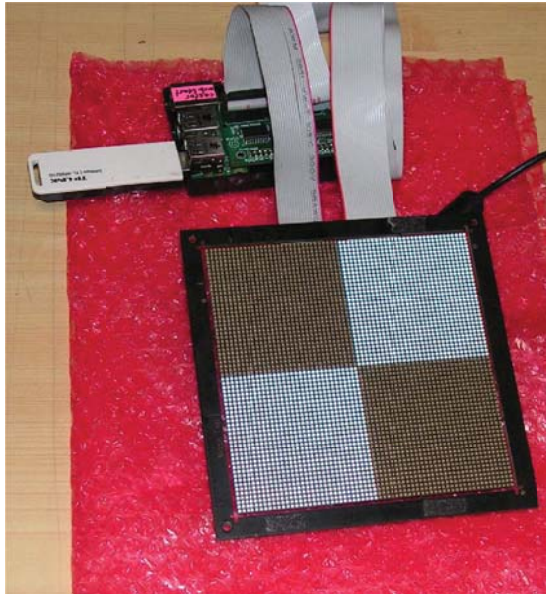

Fig. 4. LED display module

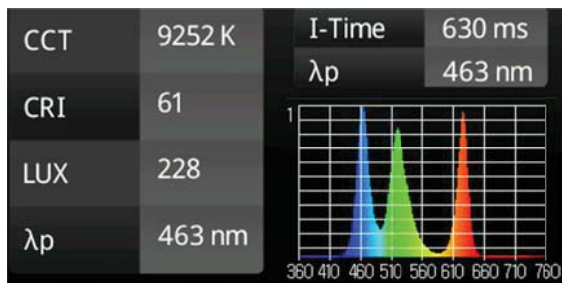

Fig. 5. Spectral characteristics

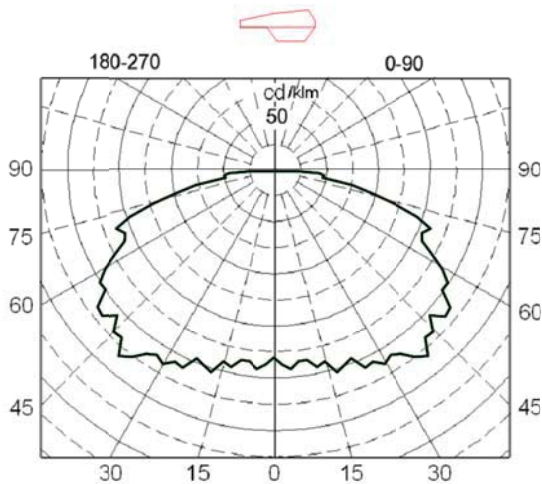

Fig. 6. Light distribution of the display module

## Conclusion

The established measurement system has been tested by performing a control measurement of a LED module designed to produce a display. Tests have shown its efficiency.

Guidelines for future system upgrading - mounting an extra camera to capture portions of the display. From the captured images, defective pixels, spacing pixels and nonlinearities are determined directly.

## References

1. <https://fakti.bg/technozone/196546-v-aponia-pusnaha-8k-televizia>
2. <http://news.desktop.bg/novini/amd-radeon-pro-uspya-da-se-spravi-i-s-16k-rezolyutsiya-15-360-x-8640/>
3. БДС EN 61747-4 Liquid crystal display devices - Part 4: Liquid crystal display modules and cells - Essential ratings and characteristics (IEC 61747-4:2012)
4. БДС EN 61747-4-1, Liquid crystal display devices - Part 4-1: Matrix colour LCD modules - Essential ratings and characteristics
5. БДС EN 61747-5, Liquid crystal and solid-state display devices, Part 5: Environmental, endurance and mechanical test methods (IEC 61747-5:1998)
6. БДС EN 61747-5-2, Liquid crystal display devices -- Part 5-2: Environmental, endurance and mechanical test methods - Visual inspection of active matrix colour liquid crystal display modules
7. БДС EN 61747-6, Liquid crystal and solid-state display devices Part 6: Measuring methods for liquid crystal modules – Transmissive type
8. БДС EN 61747-6-2, Liquid crystal display devices -- Part 6-2: Measuring methods for liquid crystal display modules - Reflective type
9. БДС EN 61747-6-3, Liquid crystal display devices -- Part 6-3: Measuring methods for liquid crystal display modules - Motion artifact measurement of active matrix liquid crystal display modules
10. БДС EN 61747-10-1, Liquid crystal display devices - Part 10-1: Environmental, endurance and mechanical test methods - Mechanical
11. БДС EN 61747-30-1, Liquid crystal display devices -- Part 30-1: Measuring methods for liquid crystal display modules - Transmissive type
12. EN 62629-1-2 August 2013, 3D Display devices - Part 1-2: Generic -Terminology and letter symbols (IEC 62629-1-2:2013)
13. БДС EN 62629-22-1, May 2013, 3D display devices -Part 22-1: Measuring methods for autostereoscopic displays - Optical (IEC 62629-22-1:2013)

The article is reviewed by Assoc. Prof. Dr. Rumen Istalianov and Assoc. Prof. Dr. Todor Varbev.